



23001 Industrial Blvd, Rogers, MN 55374 / 1-866-527-7637
www.motoalliance.com

VIPER Winch Mount

MA11928

Yamaha 2016+ Grizzly (all models)

Yamaha 2016+ Kodiak 700 (all models)

Thank you for purchasing our VIPER winch mount. You now own a premium custom winch mount which allows you to use your winch with your ATV. Please note the following instructions and heed all warnings.

- Please use common sense when operating your ATV
- Read your Winch Operator Manual and all other operator manuals, including warning labels, before operating your ATV
- Be observant of moving parts causing entanglement, use extreme caution!

SEVERE INJURY OR DEATH MAY RESULT IF YOU ARE NEGLIGENT.

MA11928

VIPER Yamaha Grizzly and Kodiak Winch Mount



motoalliance

23001 Industrial Blvd

Rogers, MN 55374

866.527.7637

Please verify that all hardware and parts are included in your package.

Kit Contents:

Part #	Description	Qty
1	MA11928 Mount Plate	1
2	3/8"-16 x 1" Grade 5 Carriage Bolt	2
3	3/8"-16 Serrated Flange Nut	2
4	M10-1.25x20mm Grade 5 Hex Bolt	2
5	M10 Split Lock Washer	2
6	M10 Flat Washer	2

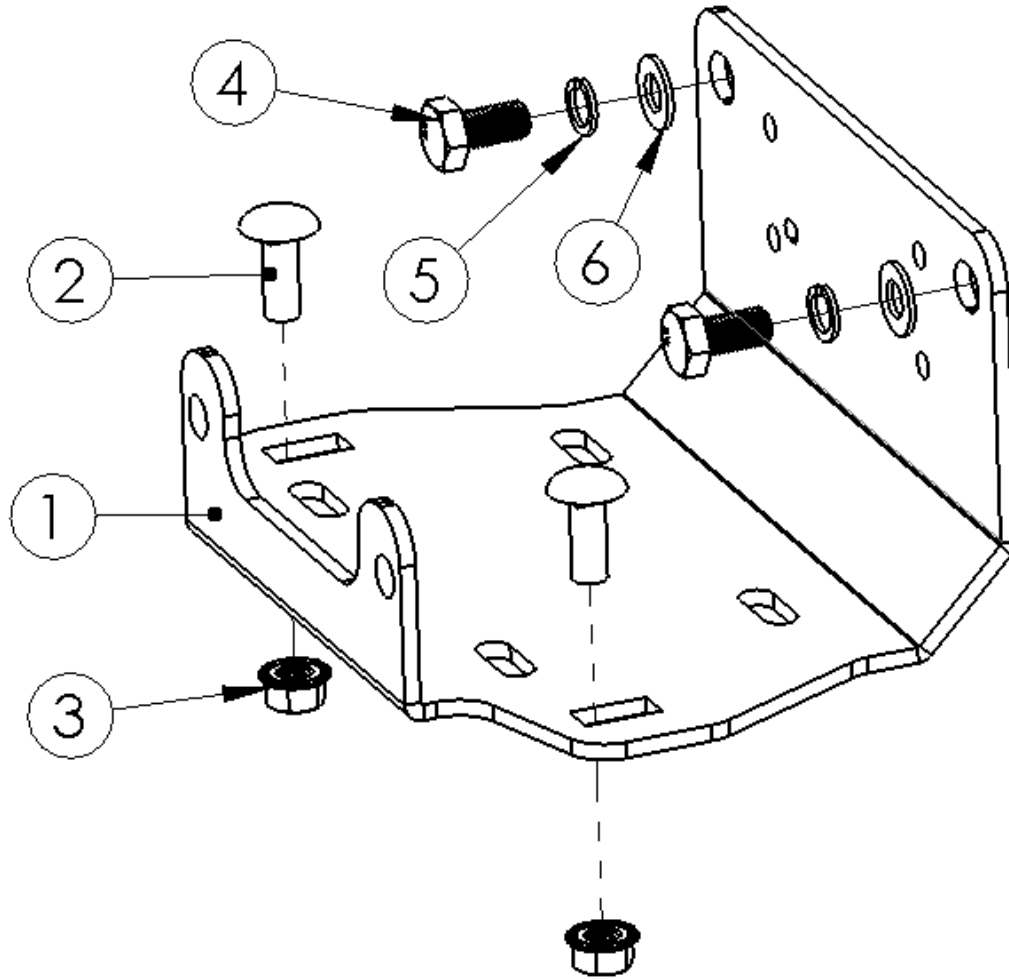

MA11928 Winch Mount Assembly View



- 1) Remove the four (4) bolts that hold the front plastic brush guard to the frame of the vehicle as shown in Figure 1. Set aside the brush guard.

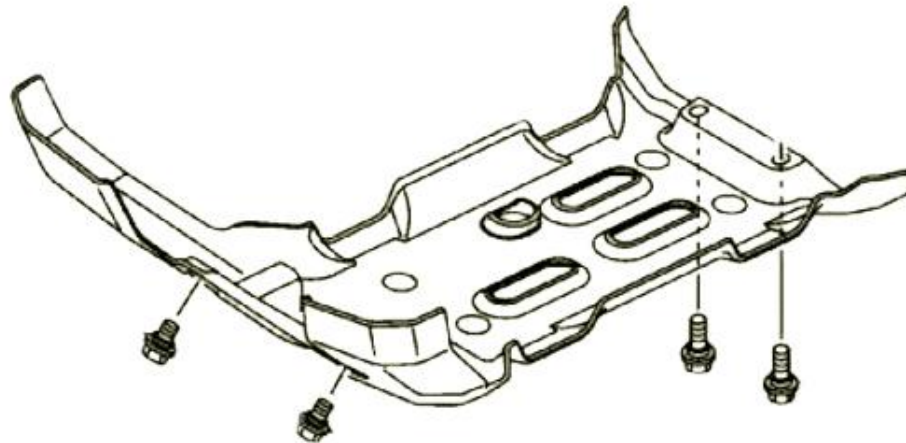

Figure 1

- 2) Position the MA11928 Mount Plate (part #1) between the metal front bumper and the vertical uprights that support the radiator as shown in Figure 2.



Figure 2



- 3) Loosely install two (2) M10-1.25 x 20mm Hex Bolts (part #4), M10 Split Lock Washers (part #5) and M10 Flat Washers (part #6) to the back of the MA11928 Mount Plate (do not tighten completely at this time).
- 4) Insert the two 3/8"-16 x 1" Carriage Bolts (part #2) from the top of the winch mount and loosely secure using the 3/8"-16 Serrated Flange Nuts (part #3).
Installation note: The MA11928 Mount Plate is designed to have a slight amount of tension in it when the mount is fully tightened.
- 5) Tighten all hardware.
- 6) The majority of ATV contactors can be mounted to the reverse side of the winch mount. Attach using the hardware included with your contactor as shown in Figure 3.

Examples of these contactors are found below:



MX-028



MX-228

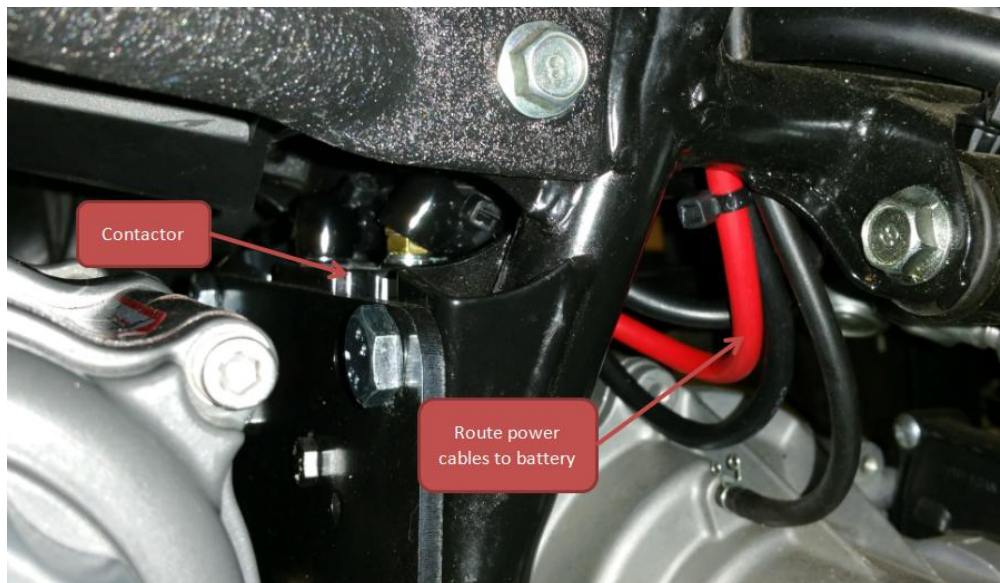

Figure 3



- 7) Position the winch over the MA11928 Mount Plate with the winch motor toward the front right tire of the ATV. Secure it using the hardware included with the winch kit.
- 8) Before working on any 12V electrical system, disconnect the negative battery terminal from the vehicle battery and secure it away from the battery terminals.
- 9) VIPER winches include two sets of power cables, a short set and a long set. Use the short set of cables to connect the contactor to the winch and the longer set to connect the contactor to the battery.

Installation Note: In this configuration, the cable colors may not match the contactor and winch terminal post colors as shown in Figure 4.

1. Connect the Yellow/Blue contactor terminals to the winches Yellow/Blue terminal posts using the shorter power cables regardless of the cable color. Match post color to post color.
2. Connect the Red contactor post to the positive 12V terminal of the battery regardless of the cable color used.
3. Connect the Black contactor post to the negative battery terminal regardless of the cable color used.

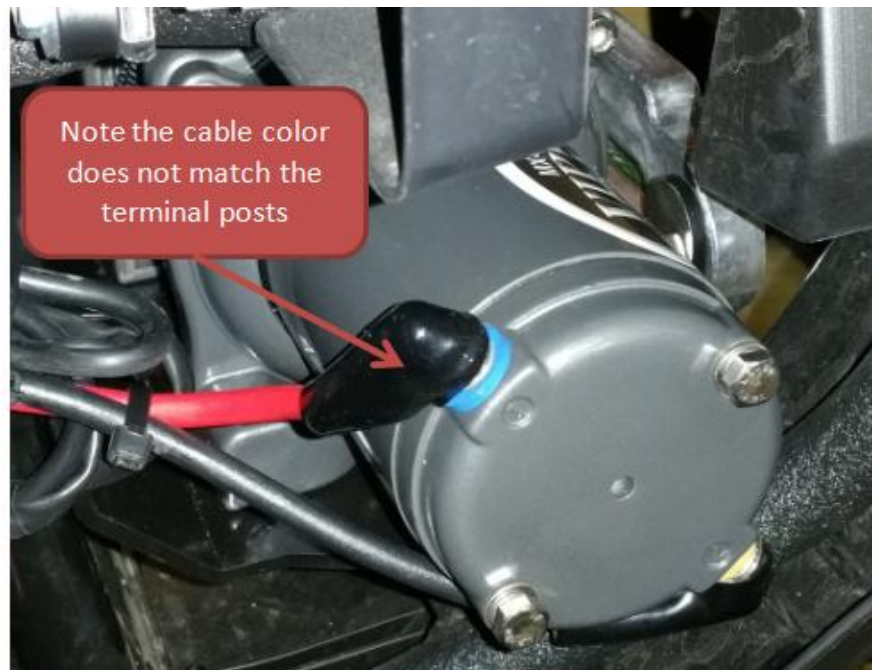

Figure 4

MA11928

VIPER Yamaha Grizzly and Kodiak Winch Mount



motoalliance

23001 Industrial Blvd

Rogers, MN 55374

866.527.7637

-
- 10) If installing a handle bar switch, remove the plastic steering column covers to gain access to the OEM wiring harness. Attach the switch and route the cables with the factory wires. Ensure the wires can move freely when the steering column is turned.
 - 11) Attach the switch to the winch contactor per the manufacturer's recommendation and attach the switch to a keyed power source.
 - 12) Turn the key to the accessory position and test that the winch moves in/out according to the desired direction.